

## TOUCH II

7" touchscreen, user friendly and totally programmable.  
 Videos on display, ads, instructions.  
 37 Languages.  
 Free software for programming, telemetry, data analysis.  
 USB Connection

## G FORCE

G-FACTOR 200: 25 - 100 Lbs.  
 G-FACTOR 150: 135- 180 Lbs.

## EFFICIENCY

Intelligent consumption: automatic adjustment of water and soap consumptions (standard).  
 Optimal loading: manual indication of weight.  
 Low water consumption.

## VERSATILITY

Custom - Make to order.  
 OPL or Self-service.  
 Electric or Hot water.  
 Wet cleaning features.

## CONNECTIVITY

IoT - **DOMUSCONNECT** standard.  
 Remote technical service.  
 Management of laundries: self-service & OPL.

## ERGONOMICS

Reversible doors.  
 Large Loading doors:  
 • Ø 373 (25, 30 Lbs.)  
 • Ø 460 (40, 50, 65 Lbs.)  
 • Ø 560 (80 ,100, 135 lbs.)

## MAINTENANCE

Hinged control panel: easy and ergonomic access.  
 Technical menu: statistics for technicians.  
 Equivalent parts for all models: electronic parts, contactors.

## OTHERS

Hard mounted washers.  
 Anchoring to floor with anchoring base.  
 Panels in skin plate.  
 3 water inlets.  
 CB and WRAS approved product.



## OPTIONS

- License IoT - Domus Connect
- Ready for ECOTANK conn. 3/4" for washers DLU/DHU-25-65
- EXTRA DOSING PUMP DB-1
- SLUICE - Drum with 0.31 In holes for DLU-50
- Anchoring base for DLU-50
- Double drain kit for DLU-40/50/65/80C/100C
- Normally closed valve DLU-40/50
- 6 extra dosing signals card for DLU-25 to DLU-100C
- Silicon gasket DLU-40/50
- Reverse door opening
- Tropicalized model: protected board (TOUCH II)
- Stainless steel AISI 304 outer casing for DLU-50
- Stainless steel AISI 304 top and front panel for DLU-50
- Auto unlock kit for the door (in case of power failure) DLU-DHU

DRUM	UNIT.	DLU-50 TOUCH II	
Capacity 1/9	Lb.	55.1	
Capacity 1/10	Lb.	48.5	
Volume	Cu.Ft	7.8	
Diameter	in	27.6	
Depth	In	22.1	
GENERAL DETAILS			
Washing speed / Spinning speed	r.p.m.	50/714	
G Factor	-	200	
Maximum force transmitted	KN	3.04 ±5	
Frequency-dynamic force	Hz	8.42	
Noise level	dB	<70	
Coin laundry version	-	Yes	
Double drain	-	Opt.	
Weighing system / Tilting door	-	No	
SLUICE option	-	Yes	
DOOR			
Height center door / Height door	In	25.8/13.7	
Diameter	In	18.1	
POWER			
Motor	Hp	3	
Electric heating power	kW	12	
Total electric power (electric model)	kW	12.75	
Total electric power (hw, steam model)	kW	2.2	
CONNECTIONS		E	HW/S
Voltage 208-240/60/1~ + G	Nº x AWG / A	3 x 10 / 70A	3 x 14 / 15A
Voltage 230/3~ + G	Nº x AWG / A	4 x 8 / 40A	-
Voltage 440-480/3 ~ + G	Nº x AWG / A	4 x 10 / 30A	-
Steam inlet (Steam model)	inch	1/2"	
Maximum steam consumption (Steam model)	Kg/h	12	
Water inlet	inch	3/4"	
Water main pressure	Kgs/cm <sup>2</sup>	2-4	
Maximum water consumption*	Gal/h	31.7*	
Drain	mm/inch	3"	
Drainage capacity	Gal/min	52.8	
DIMENSIONS / PACKING DIMENSIONS			
Net Width/Gross width	In	31.02/33.5	
Net Depth/Gross depth	In	40.75/43.6	
Net Height / Gross height	In	51.46/62.4	
Net weight / Gross weight	Lb.	650.5/738.7	
Volume	Ft3	53	

\* Program No. 20: DLU-25 to DLU-100C with 75% load and program no. 2: DLU-135C and 180C with 100% load

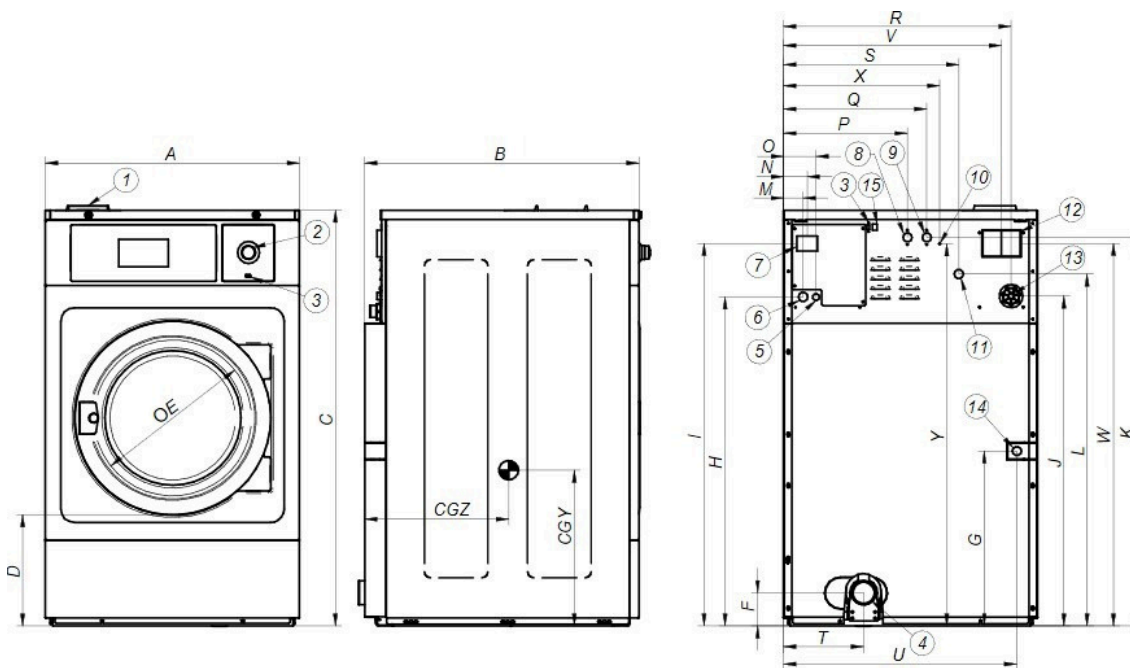

1. Soap dispenser
2. Emergency stop
3. USB port
4. Drain
5. Electric connection to liquid soap pumps
6. Electrical connection
7. Main switch
8. Auxiliary water inlet
9. Hot water inlet
10. Equipotential connection
11. Cold water inlet
12. Blur output / Water overload
13. Liquid soap connection
14. Steam connection
15. Ethernet port
16. Clean side light

		A	B	C	D	E	F	G	H	I	J	K	L	M	N	O	P	Q	R	S	T	U	V	W	X	Y	CGY	CGZ
DLU-50	mm	788	1035	1307	348	460	143	552	1035	1203	1038	1222	1107	61	74	101	385	445	706	545	245	724	676	1202	485	1202	479	546
	inch	31.02	38.20	51.46	13.70	18.11	4.63	21.73	40.75	47.36	40.87	48.11	43.58	2.40	2.91	3.98	15.16	17.52	27.80	21.42	9.56	28.50	26.61	47.32	19.09	47.32	18.86	21.50