

Hoffman

BC Dry Cleaning Press



The new revolutionary design dry cleaning press.

INNOVATIVE FEATURES:

- Compact frame – minimal floor space
- Extremely quiet and smooth operation
- Simplified pneumatic control system for easy maintenance and reliability
- Lock with pressure or no-lock selector switch
- Ergonomic soft touch operating buttons and foot pedals for operator comfort
- Extra wide head opening provides easy access to and unrestricted view of the garment
- Heavy-duty steel frame and linkage for exceptional durability

AVAILABLE OPTIONS:

- Digital release timer
- Swing-away sleeve board with vacuum
- Steam/electric iron and lowboy
- All-steam iron
- Water spray gun and condenser
- ASME certification
- CE certification
- Steam vacuum valve
- Cast aluminum head
- Left hand head and buck mounting
- Wide selection of head and buck shapes

Optional Sleever & Iron with Stand



BC-42

HOFFMAN
The First Name In Pressing

TECHNICAL DATA:

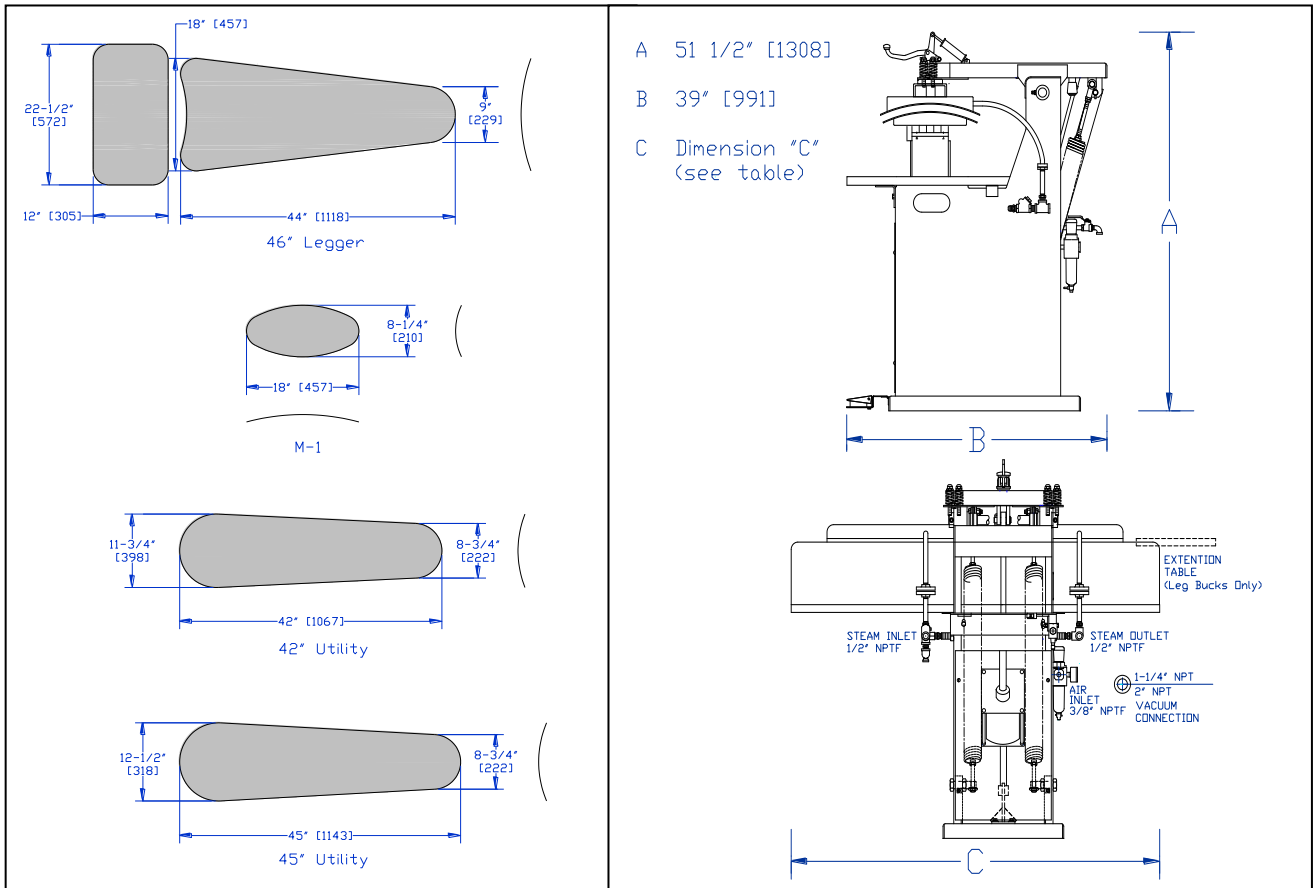

TECHNICAL SPECIFICATIONS:		
	BC-42	BC-45
Steam Consumption @ 80 psig	30 lb/hr [13.6 kg/hr]	30 lb/hr [13.6 kg/hr]
Max. Steam Pressure	125 psi [862 KPa]	125 psi [862 KPa]
Air Consumption Free Air per Cycle @ 80 psi	0.69ft ³ [0.02 M ³]	0.69ft ³ [0.02 M ³]
Max. Air Pressure	80 psi [552 KPa]	80 psi [552 KPa]
Vacuum Size – NPT Female	1-1/4"	1-1/4"
Voltage	120/220	120/220
Table Length – Dim. "C"	51" [1295 mm]	51" [1295 mm]
Net Machine Weight	575 lb [260 kg]	590 lb [267 kg]
Shipping Weight	625 lb [283 kg]	640 lb [290 kg]
	BCM-1	BC-46T
Steam Consumption @ 80 psig	22 lb/hr [10 kg/hr]	30 lb/hr [13.6 kg/hr]
Max. Steam Pressure	125 psi [862 KPa]	125 psi [862 KPa]
Air Consumption Free Air per Cycle @ 80 psi	0.69ft ³ [0.02 M ³]	0.69ft ³ [0.02 M ³]
Max. Air Pressure	80 psi [552 KPa]	80 psi [552 KPa]
Vacuum Size – NPT Female	1-1/4"	2"
Voltage	120/220	120/220
Table Length – Dim. "C"	27" [686 mm]	48" [1219 mm]
Net Machine Weight	460 lb [208 kg]	625 lb [283 kg]
Shipping Weight	505 lb [229 kg]	675 lb [305 kg]



Hoffman/New Yorker, Inc.
 46 Clinton Place, Hackensack, NJ 07601
 Tel: 201-488-1800 Fax: 201-488-4480
www.hoffman-newyorker.com

DISTRIBUTED BY:



Equipment is subject to manufacturer's standard warranty. Accuracy of illustration and description of equipment shown herein applies to product.

5610 McAdam Road, Mississauga, Ontario L4Z 1P1
 905.890.1220 • 800.387.9503 • Fax: 905.890.7039
 email: harco@harco.com • www.harco.com